

# 軸付砥石(軸径φ3.0mm) Grinding Points

● WA / ビトリファイド(茶褐色)



最も普及している汎用砥石です。破碎性と硬度のバランスが良く、使い易く軽研削に適します。

● 一般鋼材・普通炭素鋼・合金鋼

The most popular general-purpose grinding stone. It has a good balance of crushability and hardness, is easy to use, and is suitable for light grinding.

● For grinding general steel, ordinary carbon steel, alloy steel, etc.

○ WA / ビトリファイド(ホワイト)



破碎性があり、シャープな切れ刃が出やすく、硬度のある焼入れ鋼にも適します。

○ 一般焼入れ鋼・工具鋼・合金鋼

It has good crushability, is easy to produce sharp cutting edges, and is suitable for hardened steel.

○ For grinding general hardened steel, tool steel, alloy steel, etc.

● A / ビトリファイド(グレー)



WA砥石に比較し、破碎しにくく消耗が少ない。低硬度な金属などの重研削に適します。

● 一般鋼材・生鋼材・鋳鉄・低硬度の金属

Compared to WA grinding stones, it is harder to crush and wears less.

● For grinding general steel, raw steel, cast iron, low-hardness metal, etc.

Max Rev  
90,000min<sup>-1</sup>

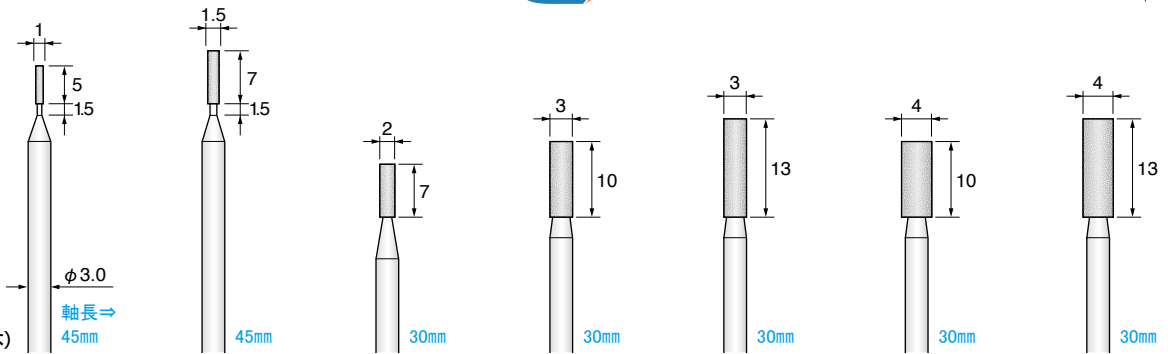

\* 販売最小単位(50本)

WA(茶褐色)	SB0101 #320	SB0102 #320	SB0103 #120	SB0104 #80	SB0105 #80	SB0106 #80	SB0107 #80
WA(ホワイト)	SB0201 #320	SB0202 #320	SB0203 #120	SB0204 #80	SB0205 #80	SB0206 #80	SB0207 #80
A(グレー)	—	—	—	SB0304 #80	SB0305 #80	SB0306 #80	SB0307 #80
PA(ピンク)	SB0401 #320	SB0402 #320	SB0403 #220	SB0404 #120	SB0405 #120	SB0406 #120	SB0407 #120
GC(グリーン)	SB0501 #320	SB0502 #320	SB0503 #150	SB0504 #120	SB0505 #120	SB0506 #120	SB0507 #120
A(ブラック)	—	—	—	SB0604 #80	—	SB0606 #80	SB0607 #80

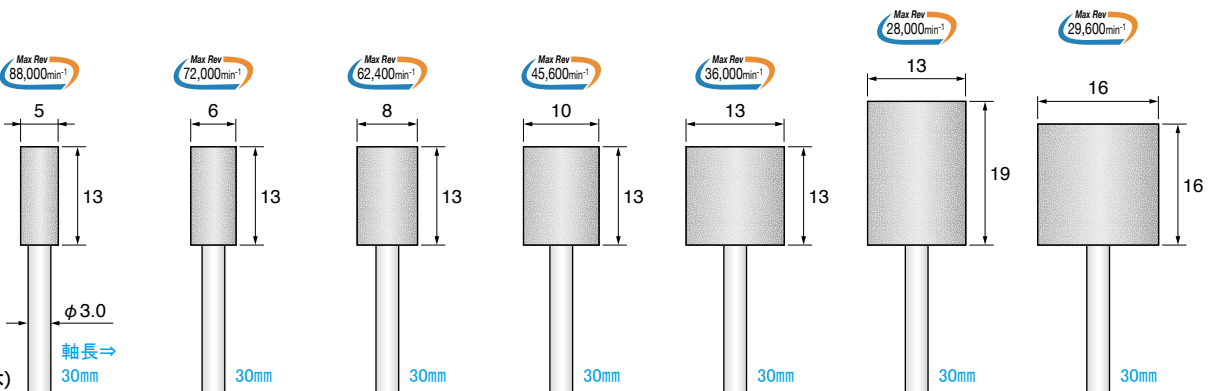

\* 販売最小単位(50本)

WA(茶褐色)	SB0108 #60	SB0109 #60	SB0110 #60	SB0111 #60	SB0112 #60	SB0113 #60	SB0114 #60
WA(ホワイト)	SB0208 #60	SB0209 #60	SB0210 #60	SB0211 #60	SB0212 #60	SB0213 #60	SB0214 #60
A(グレー)	SB0308 #60	SB0309 #60	SB0310 #60	SB0311 #60	SB0312 #60	SB0313 #60	SB0314 #60
PA(ピンク)	SB0408 #120	SB0409 #120	SB0410 #120	SB0411 #120	SB0412 #120	SB0413 #80	SB0414 #80
GC(グリーン)	SB0508 #120	SB0509 #120	SB0510 #120	SB0511 #120	SB0512 #120	SB0513 #120	SB0514 #120
A(ブラック)	SB0608 #80	SB0609 #60	SB0610 #36	SB0611 #36	SB0612 #36	SB0613 #36	SB0614 #36