

あらゆる加工現場の最前線で活躍する、SGW $\phi 3.0\text{mm}$ 軸付砥石シリーズです。
5砥粒6種類の砥石から用途に応じてお選びいただけます。

A series of SGW grindstones with $\phi 3.0\text{mm}$ shank that are active at the forefront of all processing sites.
With 5 types of abrasive grains, you can choose from 6 types of grindingstones according to your application.

● PW / ビトリファイド(ピンク)

● GC / ビトリファイド(グリーン)

● A / レジノイド(ブラック)



WA砥石に比較して研削性、砥粒切れ刃の保持力が高く耐久性に優れます。金型加工等に適します。

● インコネル・耐熱合金・ステンレス鋼・工具鋼・合金鋼の焼入れ品

Compared to WA grinding stones, it has high grindability and holding power of the abrasive grain cutting edge, and has excellent durability. Suitable for mold processing, etc.

- For grinding Inconel, heat-resistant alloy, stainless steel, tool steel, alloy hardened steel, etc.

一般砥粒としては最も硬度が高いため、破砕性が良く硬くて粘りの無い被削材に適します。

● 超硬合金・ガラス・セラミックス・非鉄金属のバリ取り

Since it has the highest hardness as a general abrasive grain, it is suitable for work materials with good crushability, hardness, and low viscosity.

- For deburring of cemented carbide, glass, ceramics, and non-ferrous metals, etc.

鋭い切れ味が最大ポイント!! 目詰まりが少なく作業効率を限界まで高める優れた砥石です。

フェノール樹脂結合剤により、適度な弾性をもち、切削時の跳ね返りが少なく作業者に優しい砥石です。

● 一般鋼材・ステンレス鋼・鋳鉄・アルミニウムの研削

An excellent grinding stones with excellent sharpness, less clogging, and maximizing work efficiency.

- It is a grinding stones that has moderate elasticity due to the phenolic resin binder, has less rebound during cutting, and is friendly to workers.
- For grinding of general steel, stainless steel, cast iron, and aluminum, etc.

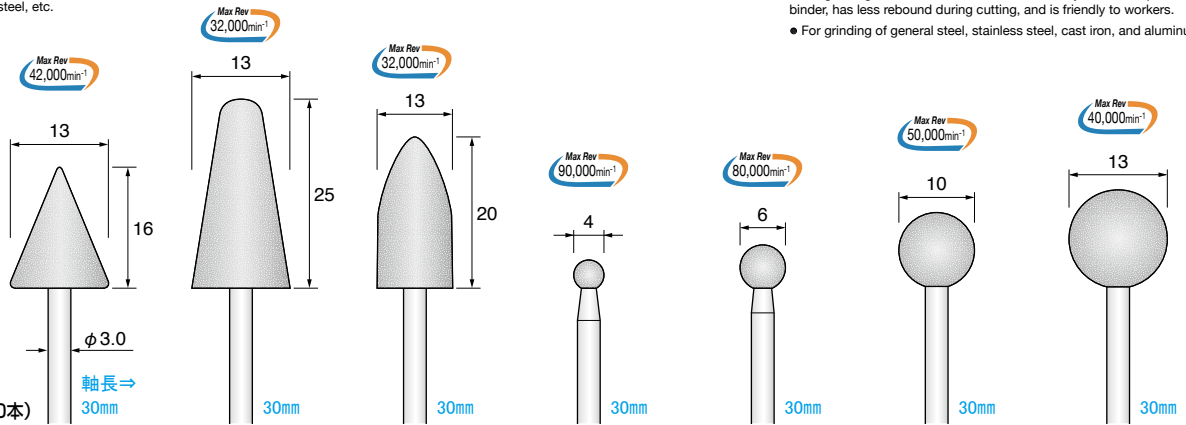

* 販売最小単位(50本)

WA(茶褐色)	SB0115 #80	SB0116 #60	SB0117 #60	SB0118 #120	SB0119 #80	SB0120 #80	SB0121 #60
WA(ホワイト)	SB0215 #60	SB0216 #60	SB0217 #60	SB0218 #120	SB0219 #80	SB0220 #60	SB0221 #60
A(グレー)	SB0315 #60	SB0316 #60	SB0317 #60	SB0318 #120	SB0319 #80	SB0320 #60	SB0321 #60
PA(ピンク)	SB0415 #80	SB0416 #80	SB0417 #100	SB0418 #120	SB0419 #120	SB0420 #120	SB0421 #80
GC(グリーン)	SB0515 #120	SB0516 #120	SB0517 #100	SB0518 #120	SB0519 #100	SB0520 #100	SB0521 #100
A(ブラック)	—	SB0616 #36	—	—	—	—	—

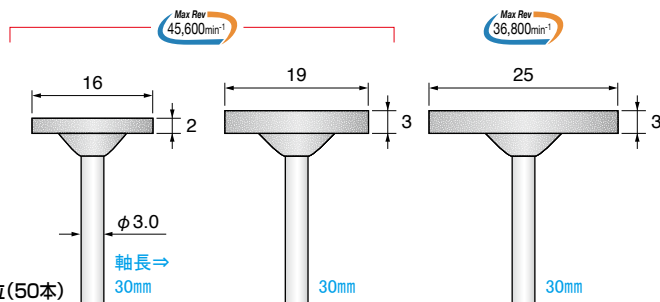

* 販売最小単位(50本)

WA(茶褐色)	SB0122 #60	SB0123 #60	SB0124 #60
WA(ホワイト)	SB0222 #60	SB0223 #60	SB0224 #60
A(グレー)	SB0322 #60	SB0323 #60	SB0324 #60
PA(ピンク)	SB0422 #80	SB0423 #80	SB0424 #80
GC(グリーン)	SB0522 #120	SB0523 #120	SB0524 #120
A(ブラック)	SB0622 #36	SB0623 #36	SB0624 #36

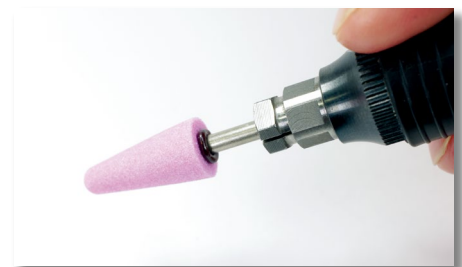

● PW(ピンク)砥石の装着イメージ

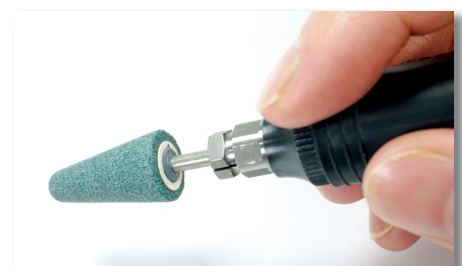

● GC(グリーン)砥石の装着イメージ